



# Technical Product Datasheets

(2021-6)

 QUALITÄT AUS  
DEUTSCHLAND

# Contents Technical Product Datasheets

Updated: 01.06.2021

Château by adler.....	2
Tableau by adler .....	4
Villa by adler incl. Herringbone & Chevron .....	6
Villa by adler 35.....	8
Villa by adler 35 RUSTICO.....	10
Profi by adler Hardwood.....	12
Profi by adler Softwood .....	14
Maxi by adler 35.....	16
Maxi by adler 35 RUSTICO .....	18
Elegance by adler incl. Herringbone & Chevron .....	20
Elegance by adler 600 incl. Herringbone & Chevron .....	22
Basic by adler LONG.....	24
Overview of our factory gradings .....	26

## Adler Parkett

Furnierwerk Anton Luib KG-Nachfolger

Allgäuer Str. 26

D-87742 Dirlewang

Telefon: +49-(0)8267-96 95-0

Email: [info@adler-parkett.de](mailto:info@adler-parkett.de)

Website: [www.adlerparkett.com](http://www.adlerparkett.com)



General	Exclusive planks with wide widths and long lengths 3 ply construction Multilayer wooden floorboards according EN14342:2013
Species / Dimensions	European <b>Oak</b> : Widths random from 180 - 350 mm / Lengths random from 1,8 – 5,0 m European <b>Larch</b> : Widths random from 180 - 300 mm / Lengths random from 3,0 – 5,0 m European <b>Douglas</b> : Widths random from 160 – 350 mm / Lengths random till 5,0 m American <b>Walnut</b> : Widths random from 160 - 350 mm / Lengths random till 4,0 m European <b>Ash</b> brown: Widths random from 160 – 300 mm / Lengths random till 5,0 m  Smaller lengths and widths are included  In Oak and Douglas longer lengths from 5,0 up to 10,0 m can be produced – on request – according availability of raw material
Total Thickness	19 mm
Construction	Top Layer made out of sawn cut veneers of approx. 4,5 mm For special surface finishes rough sawn, planed and hand-scraped, the top layer on the plank can vary between 2.5 and 4.0 mm Each top layer is dried individually to a moisture content of $8 \pm 2 \%$ Core out of solid spruce Counterbalance made out of Spruce veneer
Glue	White glue (PVAc-glue)
Bevel	As standard produced with 4sides bevel
Head Machining	Heads are grooved with lose tongue included
Packaging	On request and against invoice we pack in a special wooden box for secure transport
Grading	According to our factory grade we deliver a random quality eg.: vibrant to tranquil; there is a possibility of distinctive knots, prominent shrinkage cracks and splits; minor stress cracks as well as knot holes / flaws are filled in by hand with dark wooden filler. Boards from the central trunk area possible; sapwood may occur. On request we can offer the Oak also less knotty grading
Finish	Every finish is based on our <b>NATURA+</b> oxidatively oiled finish. In Oak either planed by hand or wire brushed depending on the requested color finish. Douglas, Walnut and Ash are only NATURA+ oiled, also available in wire-brushed version.
Color Palette	Please look up the actual offered color range of Oak and Larch in our actual price list or have a look at <a href="http://www.adlerparkett.com">www.adlerparkett.com</a> or <a href="http://www.chateaubyadler.com">www.chateaubyadler.com</a>
Color Variations	Wood is a natural product. Color may vary depending on the structure and grain of the wood. Despite taking great care during the production process, difference in color cannot be excluded from production batch to batch but also within one batch. This especially applies to colored surfaces, as wood stains and color pigments from the structure of the wood can create a range of different tones. Oak smoking processes, whether partially or core-smoked, can also lead to natural lighter or darker color variations.
Care & Maintenance	Please refer for more detailed information to our care instructions at <a href="http://www.adlerparkett.com">www.adlerparkett.com</a>

Installation	A totally glue down installation is necessary. Because of the extremely wide widths we recommend to use permanently elastic glue. Please refer for further and more detailed information to our installation instructions at <a href="http://www.adlerparkett.com">www.adlerparkett.com</a>
Underfloor Heating	This product is suitable for underfloor heating systems based on warm water: Thermal Transfer Resistance: approx. 0,16 m <sup>2</sup> k / W as to EN14342 (Oak) Max. Surface Temperature: 23 °C – 26 °C
Indoor Climate	In order to maintain the parquet's quality and for human well-being, a healthy ambient temperature of 19 - 22°C is required, at a relative humidity of approx. 50 - 60%. The floorboards may dry out severely during the heating period. This may lead to shrinkage cracks and gaps between the boards. If the floorboards are subjected to sudden moisture changes, the glued layers may experience shrinkage stress; in extreme cases leading to irreparable damage, for which we accept no liability
Classification of Fire Resistance (as to EN 13501-1)	D <sub>fl</sub> -s1 for Larch, Douglas, Walnut and Ash. C <sub>fl</sub> -s1 for our Oak products with oiled surface: (Test report VNJF 081065.2 of 07.03.16 by ÖTI / A-1050 Wien))
Emission of Formaldehyde (as to EN717-1)	E0
Emission of Pentachlorophenol (as to CEN / TR 14823)	Below limit of detection
Possible Certifications according PEFC & FSC®	On request we offer our Château planks also with 100% PEFC certificate. Depending on the possibilities of raw material we can also offer a FSC®-certified parquet floor. Please do ask.
Norms for Production	CE-Certification Planning approval for Germany: Nr. Z-156.607-801 (19.04.2018 – 14.04.2020) As we are a FSC®-certified (IMO-COC-025052) + PEFC certified (IMO-025052) production, we care that our raw materials come from responsible forestry
Site of Production	87742 Dirlewang / Germany

## TABLEAU

by adler

General	Exclusive panel parquet in multilayer construction Multilayer wooden floorboards according EN14342:2013
Specie	Depending on the pattern different species are available: European <b>Oak</b> ; European <b>Larch</b> ; American <b>Walnut</b> ;
Dimension	Depending on the type of pattern: Type A / B: 1020x1020 mm Type C / D / E: 750x750 mm
Total thickness	19 mm
Construction	Top Layer made out of sawn cut veneers of approx. 4,2 mm Each top layer is dried individually to a moisture content of $8 \pm 2 \%$ Core out of solid softwood alternatively with plywood Counterbalance made out of multi-layer plywood
Glue	White glue (PVAc-glue)
Bevel	As standard produced with 4sides bevel
Tongue and Groove	All around with groove; lose tongue included
Packaging	On request and against invoice we pack in a special wooden box for secure transport
Finish	Every finish is based on our <b>NATURA+</b> oxidatively oiled finish with different treatments
Type- / Color range	Please look up the actual offered type and color range in our actual price list or have a look at <a href="http://www.adlerparkett.com/en/panel-parquet-tableau-by-adler">www.adlerparkett.com/en/panel-parquet-tableau-by-adler</a>
Color Variations	Wood is a natural product. Color may vary depending on the structure and grain of the wood. Please keep in mind that due to the different fibre directions within the pattern light will break differently. Despite taking great care during the production process, difference in color cannot be excluded from production batch to batch but also within one batch. This especially applies to colored surfaces, as wood stains and color pigments from the structure of the wood can create a range of different tones. Oak smoking processes, whether partially or core-smoked, can also lead to natural lighter or darker color variations.
Care & Maintenance	Please refer for more detailed information to our care instructions at <a href="http://www.adlerparkett.com">www.adlerparkett.com</a>
Installation	A totally glue down installation is necessary. Because of the extremely wide widths we recommend to use permanently elastic glue. Please refer for further and more detailed information to our installation instructions at <a href="http://www.adlerparkett.com">www.adlerparkett.com</a>
Underfloor Heating	This product is suitable for underfloor heating systems based on warm water: Thermal Transfer Resistance: approx. $0,16 \text{ m}^2\text{k} / \text{W}$ as to EN14342 (Oak) Max. Surface Temperature: 23 °C – 26 °C
Indoor Climate	In order to maintain the parquet's quality and for human well-being, a healthy ambient temperature of 19 - 22°C is required, at a relative humidity of approx. 50 - 60%. The floorboards may dry out severely during the heating period. This may lead to shrinkage cracks and gaps between the boards. If the floorboards are subjected to sudden moisture changes, the glued layers may experience shrinkage stress; in extreme cases leading to irreparable damage, for which we accept no liability

Classification of Fire Resistance (as to EN 13501-1)	D <sub>fl</sub> -s1 for Larch and Walnut C <sub>fl</sub> -s1 for our Oak products with oiled surface (Test report VNJF 081065.2 of 07.03.16 by ÖTI / A-1050 Wien))
Emission of Formaldehyde (as to EN717-1)	E1
Emission of Pentachlorophenol (as to CEN / TR 14823)	Below limit of detection
Norms for Production	CE-Certification As we are a FSC®-certified (IMO-COC-025052) + PEFC certified (IMO-025052) production, we care that our raw materials come from responsible forestry
Site of Production	87742 Dirlewang / Germany

**Range of Pattern Types:**



**Type A**  
Oak or Walnut  
1020 x 1020 x 19 mm



**Type B**  
Oak  
1020 x 1020 x 19 mm



**Type C**  
Oak or Walnut  
750 x 750 x 19 mm



**Type D**  
Larch  
750 x 750 x 19 mm



**Type E**  
Larch or Oak  
750 x 750 x 19 mm



## Including Options of Herringbone and Chevron

General	<p>Single strip plank 3 layer product Multilayer wooden floorboards according EN14342:2013 240 mm width: Lengths according availability between 2200 – 2400 mm Smaller lengths possible</p>
Dimensions / Packaging	<p>2200 x 186 x 15 mm 8 Pieces / Box = 3.272 m<sup>2</sup> / Box 280 Pieces = Box x 35 = 114.520 m<sup>2</sup> / Pallet</p> <p>2400/2200 x 240 x 15 mm 2400 mm: 8 Pieces / Box = 4,608 m<sup>2</sup> / Box 224 Pieces = Box x 28 = 129,024 m<sup>2</sup> / Pallet</p> <p>Smaller widths and smaller lengths are possible and will be shipped</p>
Construction	<p>Top layer made out of sawn cut veneers of approx. 4,2 mm For special surface finishes rough sawn, planed and hand-scraped, the top layer on the plank can vary between 2.5 and 4.0 mm Each top layer is dried individually to a moisture content of 8 ± 2 % Core out of solid spruce Counterbalance made out of Spruce veneer</p>
Glue	White Glue (PVAc-glue)
Bevel	As standard with 2 sides bevels on the long sides
Species	European Oak
Grading	<p>According to our factory grade we produce the grade „standard“: sound and filled in knots and splits allowed. Small sapwood possible with 240 mm width. On request we offer „premium“grade.</p> <p>In the width of 240 mm, we also offer our "economy" assortment in two surfaces with greater knottiness, but generally without sapwood content.</p> <p>In the width of 240 mm, we also offer our grading "RUSTICO" in one surface: very rustic grading according to our factory grading with black filled knots and cracks; sapwood content permitted; in the nature of a rustic grading, there is the possibility of peeling and wind cracking. This cannot be prevented on wood with large knots and cracks, but generally without sapwood.</p>
Finish	Every finish is based on our <b>NATURA+</b> oxidatively oiled finish with wire brushed or hand scrapped or machine scrapped according to color. All finishes are produced individually according to client's order.
Color Palette	Please look up the actual offered color range of oak the actual price list or have a look at <a href="http://www.adlerparkett.com">www.adlerparkett.com</a> .
Color Variations	Wood is a natural product. Color may vary depending on the structure and grain of the wood. Despite taking great care during the production process, difference in color cannot be excluded from production batch to batch but also within one batch. This especially applies to colored surfaces, as wood stains and color pigments from the structure of the wood can create a range of different tones. Oak smoking processes, whether partially or core-smoked, can also lead to natural lighter or darker color variations.
Care & Maintenance	Please refer for more detailed information to our care instructions at <a href="http://www.adlerparkett.com">www.adlerparkett.com</a>

Installation	<p>With 186 mm wide planks floating installation is possible. Otherwise please glue down completely. On underfloor heating systems total glue down installation is necessary.</p> <p>Please refer for further and more detailed information to our installation instructions at <a href="http://www.adlerparkett.com">www.adlerparkett.com</a>.</p>
Underfloor Heating	<p>This product is suitable for underfloor heating systems based on warm water with total glue down installation:</p> <p>Thermal Transfer Resistance: ca. 0,125 m<sup>2</sup>k / W as to EN14342          Max. Surface Temperature: 25°C – 28 °C</p>
Indoor Climate	<p>In order to maintain the parquet's quality and for human well-being, a healthy ambient temperature of 19 - 22°C is required, at a relative humidity of approx. 50 - 60%. The floorboards may dry out severely during the heating period. This may lead to shrinkage cracks and gaps between the boards. If the floorboards are subjected to sudden moisture changes, the glued layers may experience shrinkage stress; in extreme cases leading to irreparable damage, for which we accept no liability</p>
Classification of Fire Resistance (as to EN 13501-1)	<p>C<sub>fl</sub>-s1 for our Oak products with oiled finish (Report VNJF 082116.2 of 28.01.16 by ÖTI / A-1050 Wien))</p>
Emission of Formaldehyde (as to EN717-1)	<p>E0</p>
Emission of Pentachlorophenol (as to CEN / TR 14823)	<p>Below limit of detection</p>
Possible Certifications according PEFC & FSC®	<p>On request we offer our Villa planks wither with PEFC or FSC®-certification. Please do ask.</p>
Norms for Production	<p>CE-certification          Planning approval for Germany: Nr. Z-156.607-801 (19.04.2018 – 14.04.2020)          As we are a FSC®-certified (IMO-COC-025052) + PEFC certified (IMO-025052) production, we care that our raw materials come from responsible forestry</p>
Site of Production	<p>87742 Dirlawang / Germany</p>

**Our possibilities of Herringbone and Chevron:**

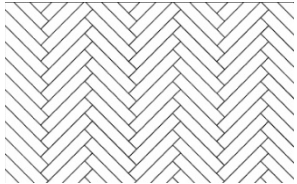
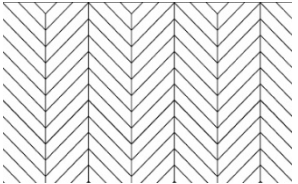
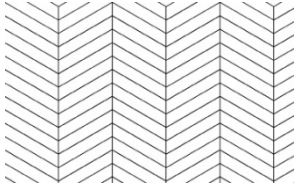
Herringbone 90°	Chevron 45°	Chevron 60°
		
<p><b>1080 x 186 x 15 mm</b> with 4 sides bevel  <b>1080/1180 x 240 x 15 mm</b> with 4 sides bevel</p>	<p><b>1000 x 186 x 15 mm</b> with 4 sides bevel  <b>1060 x 240 x 15 mm</b> with 4 sides bevel</p>	<p><b>1030 x 186 x 15 mm</b> with 4 sides bevel  <b>1120 x 240 x 15 mm</b> with 4 sides bevel</p>

In each box you have either right or left pieces





Max. Surface Temperature: 25°C – 28 °C

Indoor Climate

In order to maintain the parquet's quality and for human well-being, a healthy ambient temperature of 19 - 22°C is required, at a relative humidity of approx. 50 - 60%. The floorboards may dry out severely during the heating period. This may lead to shrinkage cracks and gaps between the boards. If the floorboards are subjected to sudden moisture changes, the glued layers may experience shrinkage stress; in extreme cases leading to irreparable damage, for which we accept no liability

Classification of Fire Resistance (as to EN 13501-1)

C<sub>fl</sub>-s1 for our Oak products with oiled finish: (Report VNJF 081067.2 of 23.09.15 by ÖTI / A-1050 Wien))

Emission of Formaldehyde (as to EN717-1)

E0

Emission of Pentachlorophenol (as to CEN / TR 14823)

Below limit of detection

Possible Certifications according PEFC & FSC®

On request we offer our Villa planks wither with PEFC or FSC®-certification. Please do ask.

Norms for Production

CE-Certification  
Planning approval for Germany: Nr. Z-156.607-801 (19.04.2018 – 14.04.2020)  
As we are a FSC®-certified (IMO-COC-025052) + PEFC certified (IMO-025052) production, we care that our raw materials come from responsible forestry

Site of Production

87742 Dirlawang / Germany



General	<p>Single strip plank 3 layer product Multilayer wooden floorboards according EN14342:2013 Lengths according availability between 1800 – 2000 mm Smaller lengths possible</p>
Dimensions / Packaging	<p>1800/2000 x 186 x 14 mm 2000 mm: 8 Pieces / Box = 2,976 m<sup>2</sup> / Box 280 Pieces = Box x 35 = 104,160 m<sup>2</sup> / Pallet</p> <p>Smaller widths and smaller lengths are possible and will be shipped</p>
Construction	<p>Top Layer made out of sawn cut veneers of approx. 3,5 mm Each top layer is dried individually to a moisture content of 8 ± 2 % Core out of solid spruce Counterbalance made out of Spruce veneer</p>
Glue	White glue (PVAc-glue)
Bevel	As standard with 2 sides bevels on the long sides
Specie	European Oak
Grading	<p>According to our factory grading we produce the grade "Rustico"</p> <p>Oak RUSTICO: a very rustic grade; sapwood possible, <u>black</u> filling. The character of a rustic and vibrant grading means that there is a possibility of brittleness and stress cracks due to shrinkage and weathering. Boards from the central trunk area possible.</p>
Finish	Every finish is based on our <b>NATURA+</b> oxidatively oiled finish with wire brushed
Color Palette	Please look up the actual offered color range of oak the actual price list or have a look at <a href="http://www.adlerparkett.com">www.adlerparkett.com</a> .
Color Variations	Wood is a natural product. Color may vary depending on the structure and grain of the wood. Despite taking great care during the production process, difference in color cannot be excluded from production batch to batch but also within one batch. This especially applies to colored surfaces, as wood stains and color pigments from the structure of the wood can create a range of different tones. Oak smoking processes, whether partially or core-smoked, can also lead to natural lighter or darker color variations.
Care & Maintaining	Please refer for more detailed information to our care instructions at <a href="http://www.adlerparkett.com">www.adlerparkett.com</a>
Installation	<p>Floating installation or total glue down installation is possible. On underfloor heating systems total glue down installation is necessary.</p> <p>Please refer for further and more detailed information to our installation instructions at <a href="http://www.adlerparkett.com">www.adlerparkett.com</a>.</p>
Underfloor Heating	<p>This product is suitable for underfloor heating systems based on warm water with total glue down installation:</p> <p>Thermal Transfer Resistance: ca. 0,122 m<sup>2</sup>k / W as to EN14342 Max. Surface Temperature: 25°C – 28 °C</p>
Indoor Climate	In order to maintain the parquet's quality and for human well-being, a healthy ambient temperature of 19 - 22°C is required, at a relative humidity of approx. 50 - 60%. The floorboards may dry out severely during the heating period. This may lead to shrinkage

cracks and gaps between the boards. If the floorboards are subjected to sudden moisture changes, the glued layers may experience shrinkage stress; in extreme cases leading to irreparable damage, for which we accept no liability

Classification of Fire Resistance (as to EN 13501-1)	C <sub>fl</sub> -s1 for our Oak products with oiled finish (Report 081067.2 of 23.09.15 by ÖTI / A-1050 Wien))
Emission of Formaldehyde (as to EN717-1)	E0
Emission of Pentachlorophenol (as to CEN / TR 14823)	Below limit of detection
Possible Certifications according PEFC & FSC®	On request we offer our Villa planks wither with PEFC or FSC®-certification. Please do ask.
Norms for Production	CE-Certification Planning approval for Germany: Nr. Z-156.607-801(19.04.2018 – 14.04.2020) As we are a FSC®-certified (IMO-COC-025052) + PEFC certified (IMO-025052) production, we care that our raw materials come from responsible forestry
Site of Production	87742 Dirlawang / Germany



General	<p>Single strip plank 3 layer product Multilayer wooden floorboards according EN14342:2013 Lengths according availability between 1800 – 2200 mm Smaller lengths possible</p>
Dimensions / Packaging	<p>1800/2200 x 146 x 15 mm 2200 mm: 8 Pieces / Box = 2,568 m<sup>2</sup> / Box 336 Pieces = Box x 42 = 107,856 m<sup>2</sup> / Pallet</p> <p>1800/2200 x 186 x 15 mm 2200 mm: 8 Pieces / Box = 3,272 m<sup>2</sup> / Box 280 Pieces = Box x 35 = 114,520 m<sup>2</sup> / Pallet</p> <p>Smaller widths and smaller lengths are possible and will be shipped</p>
Construction	<p>Top Layer made out of sawn cut veneers of approx. 4,2 mm Each top layer is dried individually to a moisture content of 8 ± 2 % Core out of solid spruce Counterbalance made out of Spruce veneer</p>
Glue	White glue (PVAc-glue)
Bevel	<p>As standard with 2 sides bevels on the long sides Exception: Ash - here with bevel on 2 sides</p>
Specie	<p>Width of 146 mm: American Black Cherry, American Walnut</p> <p>Width of 186 mm: American Walnut</p> <p>Width of 240 mm: European Ash with brownheart</p> <p>Teak: dimensions are variable according to disponibility of raw material</p>
Grading	<p>According to our factory grading we produce the grade “standard“ or “classic”</p> <p>Please look up the actual offered grading in our actual price list or have a look at <a href="http://www.adlerparkett.com">www.adlerparkett.com</a>.</p>
Finish	Our finish is based on our <b>NATURA+</b> oxidatively oiled finish.
Color Variations	Wood is a natural product. Color may vary depending on the structure and grain of the wood. Despite taking great care during the production process, difference in color cannot be excluded from production batch to batch but also within one batch.
Care & Maintaining	Please refer for more detailed information to our care instructions at <a href="http://www.adlerparkett.com">www.adlerparkett.com</a>
Installation	<p>Floating installation or total glue down installation is possible. On underfloor heating systems total glue down installation is necessary.</p> <p>Please refer for further and more detailed information to our installation instructions at <a href="http://www.adlerparkett.com">www.adlerparkett.com</a>.</p>

Underfloor Heating	<p>This product is suitable for underfloor heating systems based on warm water with total glue down installation:            Thermal Transfer Resistance: ca. 0,125 m<sup>2</sup>k / W as to EN14342            Max. Surface Temperature: 25°C – 28 °C</p>
Indoor Climate	<p>In order to maintain the parquet's quality and for human well-being, a healthy ambient temperature of 19 - 22°C is required, at a relative humidity of approx. 50 - 60%. The floorboards may dry out severely during the heating period. This may lead to shrinkage cracks and gaps between the boards. If the floorboards are subjected to sudden moisture changes, the glued layers may experience shrinkage stress; in extreme cases leading to irreparable damage, for which we accept no liability</p>
Classification of Fire Resistance (as to EN 13501-1)	D <sub>fl</sub> -s1 for Black Cherry, Walnut and Teak
Emission of Formaldehyde (as to EN717-1)	E0
Emission of Pentachlorophenol (as to CEN / TR 14823)	Below limit of detection
Possible Certifications according PEFC & FSC®	On request we offer our Profi planks with PEFC or FSC®-certification. Please do ask.
Norms for Production	<p>CE-Certification            Planning approval for Germany: Nr. Z-156.607-801 (19.04.2018 – 14.04.2020)            As we are a FSC®-certified (IMO-COC-025052) + PEFC certified (IMO-025052) production, we care that our raw materials come from responsible forestry</p>
Site of Production	87742 Dirlwang / Germany



General	<p>Single strip plank 3 layer product Multilayer wooden floorboards according EN14342:2013 Lengths according availability between 1800 – 2200 mm Smaller lengths possible</p>
Dimensions / Packaging	<p>1800/2200 x 186 x 15 mm 2200 mm: 8 Pieces / Box = 3,272 m<sup>2</sup> / Box 280 Pieces = Box x 35 = 114,520 m<sup>2</sup> / Pallet</p> <p>1800-2400 x 240 x 15 mm</p> <p>Smaller widths and smaller lengths are possible and will be shipped</p>
Construction	<p>Top Layer made out of sawn cut veneers of approx. 4,2 mm Each top layer is dried individually to a moisture content of 8 ± 2 % Core out of solid spruce Counterbalance made out of Spruce veneer</p>
Glue	White glue (PVAc-glue)
Bevel	As standard with 4 sides bevels all around (except lyed finish: square-edged)
Specie	<p>186 mm: European Larch (Austria) und Nordic Spruce</p> <p>240 mm: Douglas</p>
Grading	According to our factory grading we produce the grade "classic"
Finish	<p>Our finish is based on our <b>NATURA+</b> oxidatively oiled finish (natural or white) on an only sanded surface or a wire brushed surface according to the chosen specie.</p> <p>We offer our Douglas fir only in one color treatment in a brushed and oiled finish, which you can view on our website at <a href="http://www.adlerparkett.com">www.adlerparkett.com</a>.</p>
Color Palette	Please look up the actual offered color range of oak the actual price list or have a look at <a href="http://www.adlerparkett.com">www.adlerparkett.com</a> .
Color Variations	Wood is a natural product. Color may vary depending on the structure and grain of the wood. Despite taking great care during the production process, difference in color cannot be excluded from production batch to batch but also within one batch. This especially applies to colored surfaces, as wood stains and color pigments from the structure of the wood can create a range of different tones. Oak smoking processes, whether partially or core-smoked, can also lead to natural lighter or darker color variations.
Care & Maintaining	Please refer for more detailed information to our care instructions at <a href="http://www.adlerparkett.com">www.adlerparkett.com</a>
Installation	<p>Floating installation or total glue down installation is possible. On underfloor heating systems total glue down installation is necessary.</p> <p>Please refer for further and more detailed information to our installation instructions at <a href="http://www.adlerparkett.com">www.adlerparkett.com</a>.</p>
Underfloor Heating	This product is suitable for underfloor heating systems based on warm water with total glue down installation:

Thermal Transfer Resistance: ca. 0,133 m<sup>2</sup>k / W as to EN14342  
 Max. Surface Temperature: 25°C – 28 °C

Indoor Climate	In order to maintain the parquet's quality and for human well-being, a healthy ambient temperature of 19 - 22°C is required, at a relative humidity of approx. 50 - 60%. The floorboards may dry out severely during the heating period. This may lead to shrinkage cracks and gaps between the boards. If the floorboards are subjected to sudden moisture changes, the glued layers may experience shrinkage stress; in extreme cases leading to irreparable damage, for which we accept no liability
Classification of Fire Resistance (as to EN 13501-1)	D <sub>fl-s1</sub>
Emission of Formaldehyde (as to EN717-1)	E0
Emission of Pentachlorophenol (as to CEN / TR 14823)	Below limit of detection
Possible Certifications according PEFC & FSC®	On request we offer our Profi planks wither with PEFC or FSC®-certification. Please do ask.
Norms for Production	CE-Certification Planning approval for Germany: Nr. Z-156.607-801 (19.04.2018 – 14.04.2020) As we are a FSC®-certified (IMO-COC-025052) + PEFC certified (IMO-025052) production, we care that our raw materials come from responsible forestry
Site of Production	87742 Dirlewang / Germany





General	Single strip plank 2 layer product Multilayer wooden floorboards according EN14342:2013 Lengths according availability between 1800 – 2200 mm Smaller lengths possible
Dimensions / Packaging	Grading “classic”: 1800/2200 x 186 x 10 mm 10 Pieces / Box = 4,090 m <sup>2</sup> / Box 200 Pieces = Box x 20 = 81,800 m <sup>2</sup> / Pallet  Grading “economy”: 1800/2000 x 186 x 10 mm 10 Pieces / Box = 3,720 m <sup>2</sup> / Box 200 Pieces = Box x 20 = 74,400 m <sup>2</sup> / Pallet  Smaller widths and smaller lengths are possible and will be shipped
Construction	Top Layer made out of sawn cut veneers of approx. 3,5 mm Each top layer is dried individually to a moisture content of 8 ± 2 % Base out of solid spruce
Glue	PUR-glue
Bevel	As standard with 2 sides bevels on the long sides
Species	European Oak
Grading	According to our factory grading we produce the grade “classic” or “economy”  Please look up the actual offered gradings of oak the actual price list or have a look at <a href="http://www.adlerparkett.com">www.adlerparkett.com</a> .
Finish	Every finish is based on our <b>NATURA+</b> oxidatively oiled finish with wire brushed
Color Palette	Please look up the actual offered color range of oak the actual price list or have a look at <a href="http://www.adlerparkett.com">www.adlerparkett.com</a> .
Color Variations	Wood is a natural product. Color may vary depending on the structure and grain of the wood. Despite taking great care during the production process, difference in color cannot be excluded from production batch to batch but also within one batch. This especially applies to colored surfaces, as wood stains and color pigments from the structure of the wood can create a range of different tones. Oak smoking processes, whether partially or core-smoked, can also lead to natural lighter or darker color variations.
Care & Maintenance	Please refer for more detailed information to our care instructions at <a href="http://www.adlerparkett.com">www.adlerparkett.com</a>
Installation	Due to 2 layer construction only total glue down installation is possible.  Please refer for further and more detailed information to our installation instructions at <a href="http://www.adlerparkett.com">www.adlerparkett.com</a> .
Underfloor Heating	This product is suitable for underfloor heating systems based on warm water with total glue down installation: Thermal Transfer Resistance: ca. 0,079 – 0,090 m <sup>2</sup> k / W as to EN14342 Max. Surface Temperature: 25°C – 28 °C
Indoor Climate	In order to maintain the parquet's quality and for human well-being, a healthy ambient temperature of 19 - 22°C is required, at a relative humidity of approx. 50 - 60%. The

floorboards may dry out severely during the heating period. This may lead to shrinkage cracks and gaps between the boards. If the floorboards are subjected to sudden moisture changes, the glued layers may experience shrinkage stress; in extreme cases leading to irreparable damage, for which we accept no liability

Classification of Fire Resistance (as to EN 13501-1)	C <sub>fl</sub> -s1 for our Oak products (Report VNJF 081068.2 of 23.09.15 by ÖTI / A-1050 Wien)
Emission of Formaldehyde (as to EN717-1)	E0
Emission of Pentachlorophenol (as to CEN / TR 14823)	Below limit of detection
Possible Certifications according PEFC & FSC®	On request we offer our Maxi planks wither with PEFC or FSC®-certification. Please do ask.
Norms for Production	CE-Certification Planning approval for Germany: Nr. Z-156.607-800 (19.04.2018 – 14.04.2020) As we are a FSC®-certified (IMO-COC-025052) + PEFC certified (IMO-025052) production, we care that our raw materials come from responsible forestry
Site of Production	87742 Dirlewang / Germany



General	Single strip plank 2 layer product Multilayer wooden floorboards according EN14342:2013 Lengths according availability between 1800 – 2000 mm Smaller lengths possible
Dimensions / Packaging	1800/2000 x 186 x 10 mm 2200 mm: 10 Pieces / Box = 3,720 m <sup>2</sup> / Box 200 Pieces = Box x 20 = 74,400 m <sup>2</sup> / Pallet  Smaller widths and smaller lengths are possible and will be shipped
Construction	Top Layer made out of sawn cut veneers of approx. 3,5 mm Each top layer is dried individually to a moisture content of 8 ± 2 % Base out of solid spruce
Glue	PUR-glue
Bevel	As standard with 2 sides bevels on the long sides
Species	European Oak
Grading	Oak RUSTICO: a very rustic grade; sapwood possible, <u>black</u> filling. The character of a rustic and vibrant grading means that there is a possibility of brittleness and stress cracks due to shrinkage and weathering. Boards from the central trunk area possible.
Finish	Every finish is based on our <b>NATURA+</b> oxidatively oiled finish with wire brushed
Color Palette	Please look up the actual offered color range of oak the actual price list or have a look at <a href="http://www.adlerparkett.com">www.adlerparkett.com</a> .
Color Variations	Wood is a natural product. Color may vary depending on the structure and grain of the wood. Despite taking great care during the production process, difference in color cannot be excluded from production batch to batch but also within one batch. This especially applies to colored surfaces, as wood stains and color pigments from the structure of the wood can create a range of different tones. Oak smoking processes, whether partially or core-smoked, can also lead to natural lighter or darker color variations.
Care & Maintenance	Please refer for more detailed information to our care instructions at <a href="http://www.adlerparkett.com">www.adlerparkett.com</a>
Installation	Due to 2 layer construction only total glue down installation is possible.  Please refer for further and more detailed information to our installation instructions at <a href="http://www.adlerparkett.com">www.adlerparkett.com</a> .
Underfloor Heating	This product is suitable for underfloor heating systems based on warm water with total glue down installation: Thermal Transfer Resistance: ca. 0,079 – 0,090 m <sup>2</sup> k / W as to EN14342 Max. Surface Temperature: 25°C – 28 °C
Indoor Climate	In order to maintain the parquet's quality and for human well-being, a healthy ambient temperature of 19 - 22°C is required, at a relative humidity of approx. 50 - 60%. The floorboards may dry out severely during the heating period. This may lead to shrinkage cracks and gaps between the boards. If the floorboards are subjected to sudden moisture changes, the glued layers may experience shrinkage stress; in extreme cases leading to irreparable damage, for which we accept no liability

Classification of Fire Resistance (as to EN 13501-1)	C <sub>fl</sub> -s1 for our Oak products (Report VNJF 081068.2 of 23.09.15 by ÖTI / A-1050 Wien)
Emission of Formaldehyde (as to EN717-1)	E0
Emission of Pentachlorophenol (as to CEN / TR 14823)	Below limit of detection
Possible Certifications according PEFC & FSC®	On request we offer our Maxi planks wither with PEFC or FSC®-certification. Please do ask.
Norms for Production	CE-Certification Planning approval for Germany: Nr. Z-156.607-800 (19.04.2018 – 14.04.2020) As we are a FSC®-certified (IMO-COC-025052) + PEFC certified (IMO-025052) production, we care that our raw materials come from responsible forestry
Site of Production	87742 Dirlewang / Germany

**ELÉGANCE**  
by adler

Including Options of Herringbone and Chevron

General	Single strip short plank 2 layer construction Multilayer wooden floorboards according EN14342:2013
Dimensions / Packaging	1090 x 130 x 10 mm 12 Pieces / Box = 1,704 m <sup>2</sup> / Box 504 Pieces = Box x 42 = 71,568 m <sup>2</sup> / Pallet
Construction	Top Layer made out of sawn cut veneers of approx. 4,2 mm Each top layer is dried individually to a moisture content of 8 ± 2 % Base out of solid spruce
Glue	PUR-glue
Bevel	As standard square-edged Except, as with 2sides bevel on the long sides: Oak economy brushed, swiss oiled
Species	European Oak; American Black Cherry; American Walnut
Grading	Please look up the actual offered grading in our actual price list or have a look at <a href="http://www.adlerparkett.com">www.adlerparkett.com</a> .
Finish	Every finish is based on our <b>NATURA+</b> oxidatively oiled finish. On Oak we also offer our UV-acrylic varnish
Color Variations	Wood is a natural product. Color may vary depending on the structure and grain of the wood. Despite taking great care during the production process, difference in color cannot be excluded from production batch to batch but also within one batch. This especially applies to colored surfaces, as wood stains and color pigments from the structure of the wood can create a range of different tones. Oak smoking processes, whether partially or core-smoked, can also lead to natural lighter or darker color variations.
Care & Maintenance	Please refer for more detailed information to our care instructions at <a href="http://www.adlerparkett.com">www.adlerparkett.com</a>
Installation	Due to 2 layer construction only total glue down installation is possible.  Please refer for further and more detailed information to our installation instructions at <a href="http://www.adlerparkett.com">www.adlerparkett.com</a> .
Underfloor Heating	This product is suitable for underfloor heating systems based on warm water with total glue down installation: Thermal Transfer Resistance (10 mm): ca. 0,079 – 0,090 m <sup>2</sup> k / W as to EN14342 Max. Surface Temperature: 25°C – 28 °C
Indoor Climate	In order to maintain the parquet's quality and for human well-being, a healthy ambient temperature of 19 - 22°C is required, at a relative humidity of approx. 50 - 60%. The floorboards may dry out severely during the heating period. This may lead to shrinkage cracks and gaps between the boards. If the floorboards are subjected to sudden moisture changes, the glued layers may experience shrinkage stress; in extreme cases leading to irreparable damage, for which we accept no liability
Classification of Fire Resistance (as to EN 13501-1)	D <sub>fl</sub> -s1 for Black Cherry and Walnut C <sub>fl</sub> -s1 for our Oak products (Report VNJF 081068.2 of 23.09.15 by ÖTI / A-1050 Wien)
Emission of Formaldehyde (as to EN717-1)	E0

Emission of Pentachlorophenol (as to CEN / TR 14823)	Below limit of detection
Possible Certifications according PEFC & FSC®	On request we offer our Elegance planks with PEFC or FSC®-certification. Please do ask.
Norms for Production	CE-Certification Planning approval for Germany: Nr. Z-156.607-800 (19.04.2018 – 14.04.2020) As we are a FSC®-certified (IMO-COC-025052) + PEFC certified (IMO-025052) production, we care that our raw materials come from responsible forestry
Site of Production	87742 Dirlewang / Germany

**Our possibilities of Herringbone and Chevron:**

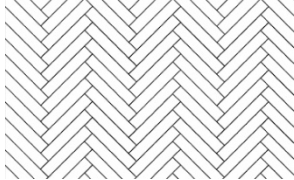
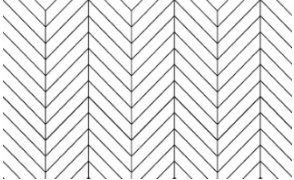
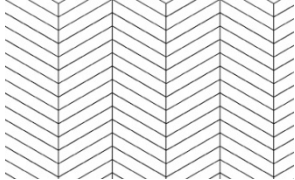
<p><b>Herringbone 90°</b></p>  <p><b>540 x 130 x 10 mm</b> with 4sides bevel <b>1090 x 130 x 10 mm</b> with 4sides bevel</p>	<p><b>Chevron 45°</b></p>  <p><b>960 x 130 x 15 mm</b> with 4sides bevel</p>	<p><b>Chevron 60°</b></p>  <p><b>1010 x 130 x 15 mm</b> with 4sides bevel</p>
--	--	--

In each box you have either right or left pieces

**ELÉGANCE 600**  
by adler

Including Options of Herringbone and Chevron



General	Single strip 2 layer construction Multilayer wooden floorboards according EN14342:2013 Suitable for Herringbone pattern, as we offer left and right pieces
Dimensions / Packaging	600 x 100 x 10 mm 36 Pieces / Box = 2,160 m <sup>2</sup> / Box 864 Pieces = Box x 24 = 51,840 m <sup>2</sup> / Pallet  Packed on EUR-Pallets.
Construction	Top Layer made out of sawn cut veneers of approx. 4,2 mm Each top layer is dried individually to a moisture content of 8 ± 2 % Base out of solid spruce
Glue	PUR-glue
Bevel	As standard with 4 sides bevels
Species	European Oak; American Walnut
Grading	According to our factory grading we produce the grade "classic"
Finish	Every finish is based on our <b>NATURA+</b> oxidatively oiled finish with wire brushed
Color Palette	Please look up the actual offered color range of oak the actual price list or have a look at <a href="http://www.adlerparkett.com">www.adlerparkett.com</a> .
Color Variations	Wood is a natural product. Color may vary depending on the structure and grain of the wood. Despite taking great care during the production process, difference in color cannot be excluded from production batch to batch but also within one batch. This especially applies to colored surfaces, as wood stains and color pigments from the structure of the wood can create a range of different tones. Oak smoking processes, whether partially or core-smoked, can also lead to natural lighter or darker color variations.
Care & Maintenance	Please refer for more detailed information to our care instructions at <a href="http://www.adlerparkett.com">www.adlerparkett.com</a>
Installation	Due to 2 layer construction only total glue down installation is possible.  Please refer for further and more detailed information to our installation instructions at <a href="http://www.adlerparkett.com">www.adlerparkett.com</a> .
Underfloor Heating	This product is suitable for underfloor heating systems based on worm water with total glue down installation: Thermal Transfer Resistance: ca. 0,079 – 0,090 m <sup>2</sup> k / W as to EN14342 Max. Surface Temperature: 25°C – 28 °C
Indoor Climate	In order to maintain the parquet's quality and for human well-being, a healthy ambient temperature of 19 - 22°C is required, at a relative humidity of approx. 50 - 60%. The floorboards may dry out severely during the heating period. This may lead to shrinkage cracks and gaps between the boards. If the floorboards are subjected to sudden moisture changes, the glued layers may experience shrinkage stress; in extreme cases leading to irreparable damage, for which we accept no liability
Classification of Fire Resistance (as to EN 13501-1)	D <sub>fl</sub> -s1 for Maple, Black Cherry and Walnut C <sub>fl</sub> -s1 for our Oak product (Report VNJF 081068.2 of 23.09.15 by ÖTI / A-1050 Wien)

Emission of Formaldehyde (as to EN717-1)	E0
Emission of Pentachlorophenol (as to CEN / TR 14823)	Below limit of detection
Possible Certifications according PEFC & FSC®	On request we offer our Elegance planks with PEFC or FSC®-certification. Please do ask.
Norms for Production	CE-Certification Planning approval for Germany: Nr. Z-156.607-800 (19.04.2018 – 14.04.2020) As we are a FSC®-certified (IMO-COC-025052) + PEFC certified (IMO-025052) production, we care that our raw materials come from responsible forestry
Site of Production	87742 Dirlewang / Germany

**Our possibilities of Herringbone and Chevron:**

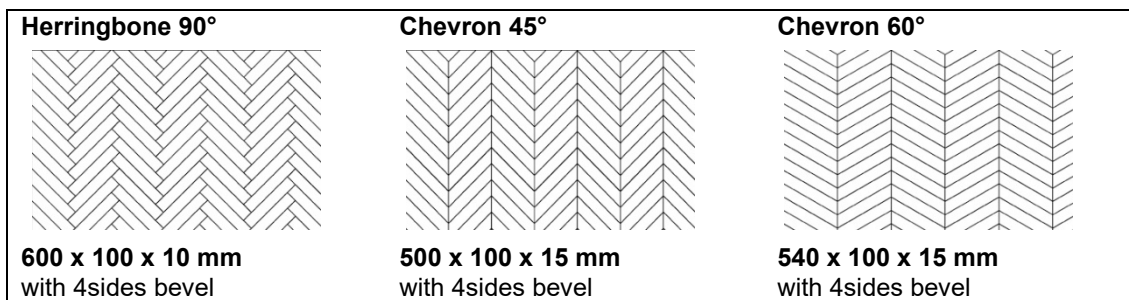

In each box you have either right or left pieces



**BASIC** LONG  
by adler

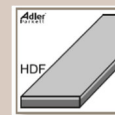

General	Single strip short plank 2 layer construction Multilayer wooden floorboards according EN14342:2013
Dimensions / Packaging	1090 x 130 x 9,5 mm 12 Pieces / Box = 1,704 m <sup>2</sup> / Box 504 Pieces = Box x 42 = 71,568 m <sup>2</sup> / Pallet
Construction	Top Layer made out of sawn cut veneers of approx. 2,8 mm Base out of HDF board
Glue	PUR-glue
Bevel	As standard square-edged
Species	European Oak
Grading	According to our factory grading we produce the grade "classic"
Finish	Every finish is based on our <b>NATURA+</b> oxidatively oiled finish with wire brushed. We do also offer our UV Acrylic varnish.
Color Variations	Wood is a natural product. Color may vary depending on the structure and grain of the wood. Despite taking great care during the production process, difference in color cannot be excluded from production batch to batch but also within one batch.
Care & Maintenance	Please refer for more detailed information to our care instructions at <a href="http://www.adlerparkett.com">www.adlerparkett.com</a>
Installation	Due to 2 layer construction only total glue down installation is possible.  Please refer for further and more detailed information to our installation instructions at <a href="http://www.adlerparkett.com">www.adlerparkett.com</a> .
Underfloor Heating	This product is suitable for underfloor heating systems based on warm water with total glue down installation: Thermal Transfer Resistance: ca. 0,060 m <sup>2</sup> k / W as to EN14342 Max. Surface Temperature: 25°C – 28 °C
Indoor Climate	In order to maintain the parquet's quality and for human well-being, a healthy ambient temperature of 19 - 22°C is required, at a relative humidity of approx. 50 - 60%. The floorboards may dry out severely during the heating period. This may lead to shrinkage cracks and gaps between the boards. If the floorboards are subjected to sudden moisture changes, the glued layers may experience shrinkage stress; in extreme cases leading to irreparable damage, for which we accept no liability
Classification of Fire Resistance (as to EN 13501-1)	Dfl-s1
Emission of Formaldehyde (as to EN717-1)	E05
Emission of Pentachlorophenol (as to CEN / TR 14823)	Below limit of detection
Norms for Certifications	CE-Certification Planning approval for Germany: Nr. Z-156.607-1448 (12.11.2014 – 12.11.2019)

As we are a FSC®-certified (IMO-COC-025052) + PEFC certified (IMO-025052) production, we care that our raw materials come from responsible forestry

Site of Production                      87742 Dirlewang / Germany

## Overview of our factory gradings

